

---

**Abstract**

A dashboard is a control panel placed in front of the driver of an automobile, housing instrumentation and controls for operation of the vehicle. The voice announcement is important because while driving, driver may not pay much attention towards the display since he is concentrating on the driving, but the voice announcement will let him hear about the alerts directly through the car speakers thereby reducing time and increasing efficiency of the system. For the Designing of such a car dashboard we are going to show the indications of car parameters like temperature, speed, rain fall ranges and fuel levels with voice feedback during car driving to the driver. The different parameter indications will be displayed on the LCD. It will also be announced through speaker using APR 9600 Re-Recording Voice IC. At the Heart of the system is the ATMEGA 32 Microcontroller which is AVR architecture based AVR Microcontroller

Thus With the help of car dashboard we can get Visual representation of performance measures and also we get voice announcement of all systems instantly.

**Keywords:** Engine Temperature, Speed of vehicle, Fuel level monitoring.

---

**Introduction**

Everybody knows the normal simple car dashboards. A nice needle showing your speed in amount of revolutions per minute, how far you drove, etc. It's simple, commonly used by the manufacturer and cheap to produce. However, design is getting more and more important, and now special colored backgrounds, special shaped dashboards are designed. Nowadays the display of amount of kilometers or miles driven is digital and more manufacturers are choosing for displaying the speed digitally as well. But, some completely digital dashboards are made.

**What is a Dashboard?**



*Figure: Dashboard Display*

Dashboard is a borrowed word from car industry. Dashboards are designed to help us monitor

what's going on at a glance-or at least, that's what they are supposed to do. Unfortunately, any time a vendor combines more than one chart on a single screen, they call it a dashboard, no matter what it's purpose, which creates a great deal of confusion. To give people a means to rapidly monitor what's going on, dashboards must be designed in particular ways to take advantage of the strengths of visual perception and cognition and to work around or augment their weakness.

**Need of Dashboard**

“Keep your eyes on the road” has been the mantra of every driver's education teacher and nervous passenger. But the fact of matter is we really don't keep our eyes on the road at all times. And that's not to say that we are engaging in dangerous behavior like texting or changing radio stations while driving-we are actually briefly averting our eyes to aid the driving experience. We refer of course, to the dashboard display.

**Hardware details**

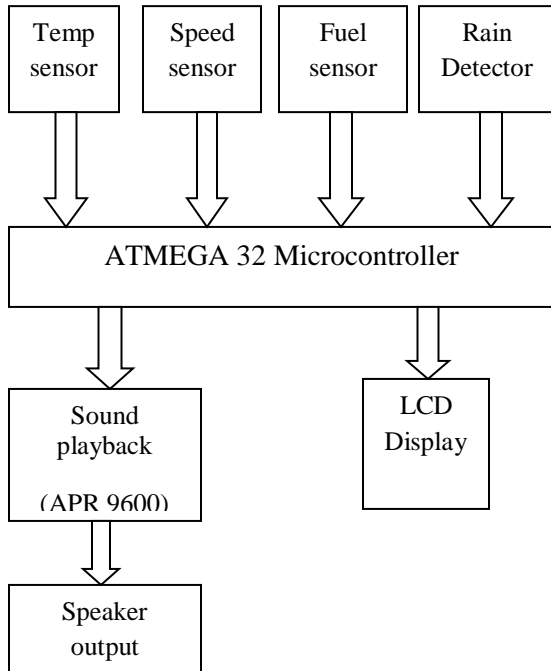

Figure: Block diagram

**Temperature sensor**



Figure: LM35 temperature sensor

LM35 temperature sensor which is factory calibrated to give accurate measurement of the temperature. It has an output voltage that is proportional to the Celsius temperature.

1. The scale factor is .01V/oC
2. The LM35 does not require any external calibration or trimming and maintains an accuracy of +/-0.4oC at room temperature and +/-0.8oC over a range of 0 oC to +100 oC.
3. Another important characteristics of the LM35DZ is that it draws only 60 micro amps from its supply and possesses a low self heating capability. The

sensor self-heating causes less than 0.1 oC temperature rise in still air.

**Speedometer Sensor**

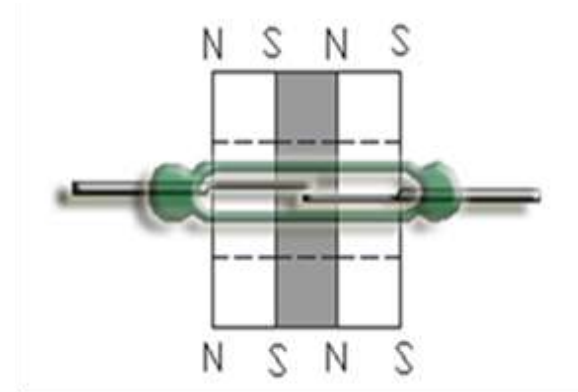

Figure: Reed switch

**What is reed switch?**

The speedometer sensor to calculate the speed of vehicle Speedometer sensor uses infrared sensors and a comparator circuit.

The basic reed switch consists of two identical flattened ferromagnetic reeds, sealed in a dry inert-gas atmosphere within a glass capsule, thereby protecting the contact from contamination. The reeds are sealed in the capsule in cantilever form so that their free ends overlap and are separated by a small air gap.

A reed sensor is a device built using a reed switch with additional functionality like ability to with stand higher shock, easier mounting, additional intelligent circuitry, etc.

**Working of Reed Switch**

When a magnetic force is generated parallel to the reed switch, the reeds become flux carriers in a magnetic circuit. The overlapping ends of the reeds become opposite magnetic poles, which attract each other. If the magnetic force between the poles is strong enough to overcome the restoring force of the reeds, the reeds will be drawn together.

**Rain Fall Sensor**

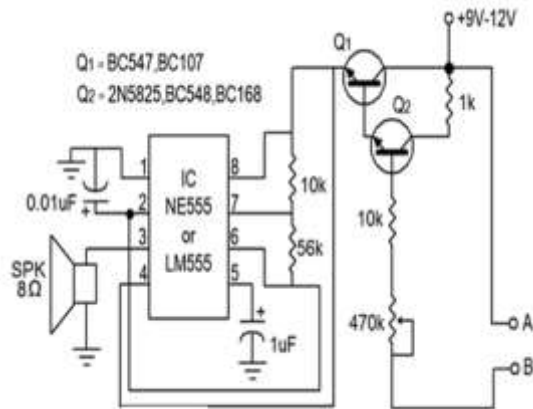

Figure: BC 547 as a Rainfall sensor

The rain fall sensor to sense the rain fall to turn the vipers on automatically.

This is a water sensor /rain alarm circuit diagram; it can be used on motorcycle, car or other device that we want to protect from water, rain.

This is a simple water sensor /rain alarm circuit that makes an alarm when water/rain falls on its sensor. This circuit is based on NE555/LM555 IC and two transistors (Q1&Q2). For transistor Q1- BC547 or BC107 and for Q2- 2N825, BC168 can be used in the circuit. This rain detector circuit can be supplied from voltage source of +9V-12V DC.

**Fuel Level Sensor**

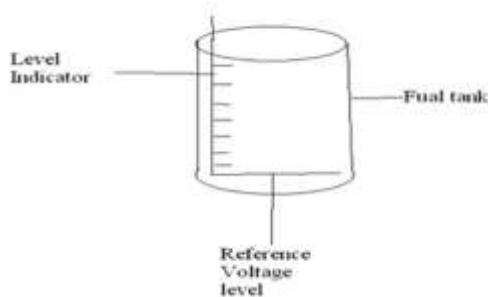

Figure: Fuel measurement system

To indicate the driver as well as fuel level sensor which sense the presence of available fuel in the vehicle. Fuel indicator system implemented using potentiometer since dipping of electronic probes is not desirable with fuel such as petrol and diesel.

**Features**

- A float type variable resistor potentiometer sensor.
- Measures the electrical resistance of level scale when no current flow.
- The signal is measured as the potential difference (voltage) between the working level and the reference level.

**Liquid Crystal Display**



Figure: LCD Display models

All the indications will be displayed on a 16X2 Liquid crystal display with Hitachi hd44780 LCD controller which gives easy interface to the microcontroller circuits.

**Features**

- LCD is finding widespread use replacing LEDs
- The declining prices of LCD
- The ability to display numbers, characters and graphics
- Incorporation of refreshing controller into the LCD, thereby relieving the CPU of the task of refreshing the LCD
- Ease of programming for characters and graphics
- Easily available everywhere
- Very easy to use
- Comes with built in controller to refresh LCD
- Provides LED Backlighting and Contrast control
- Low cost

**ATMEGA 32 microcontroller**

At the heart of the system is the ATMEGA32 microcontroller which is an AVR microcontroller

which is a low power RISC MCU working on single +5V power supply.

**Features**

- High-performance, Low-power AVR 32-bit Microcontroller.
- Advanced RISC Architecture
  - 131 Powerful Instructions
  - Most Single-clock Cycle Execution
  - 32 x 8 General Purpose Working Registers
  - Fully Static Operation
  - Up to 16 MIPS Throughput at 16 MHz
  - On-chip 2-cycle Multiplier
- High Endurance Non-volatile Memory segments
  - 32K Bytes of In-System Self-Programmable Flash program memory
  - 1024 Bytes EEPROM
  - Writes/Erase Cycles 10,000 Flash/100,000 EEPROM
  - Data retention: 20 years at 85oC/100 years at 25oC
  - Optional Boot Code Section with Independent Lock Bits
  - In-system Programming by on-chip Boot Program
  - True Read-While-Write Operation
  - Programming Lock for Software Security
- JTAG(IEEE STD. 1149.1 Compliant) Interface
  - Boundary-scan Capabilities According to the JTAG Standard
  - Extensive On-chip Debug Support
  - Programming of Flash, EEPROM, Fuses, and lock Bits through the JTAG Interface
- Peripheral Features
  - Two 8-bits Timer/Counter with Separate Prescalers and Compare Modes
  - One 16-bit Timer/Counter with Separate Prescalers and Compare Mode, and Capture Mode
  - Real Time Counter with Separate Oscillator
  - Four PWM Channels
  - 8-channel, 10-bit ADC
  - 8 Single-ended Channels
  - 7 Differential Channels in in TQFP Package Only
  - 2 Differential Channels with Programmable Gain at 1x, 10 xs, or 200 xs

- Byte-oriented Two-wire Serial Interface
- Programmable serial USART
- Master/Slave SPI Serial interface
- Programmable Watchdog Timer with Separate On-chip Oscillator
- On-chip Analog Comparator
- Special Microcontroller Feature
  - Power-on Reset and Programmable Brown-out Detection
  - Internal Calibrated RC Oscillator
  - External and Internal Interrupt Sources

**Audio module**

Additionally we've included an APR 9600 audio module, which is a DSP processor based audio playback module, which uses audio files stored in a memory card and can play the sound directly through speaker as well as a transistorized amplifier circuit.

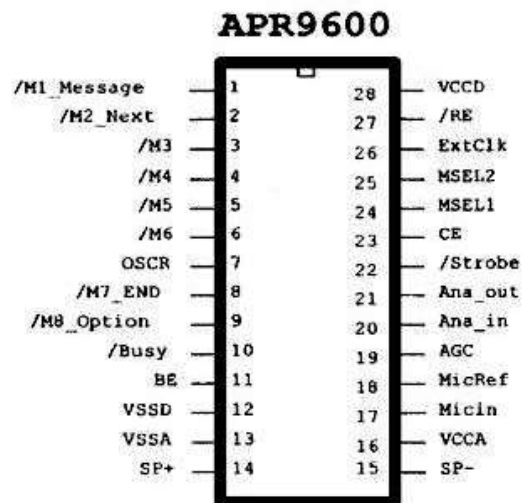

Figure: APR 9600 Pin diagram

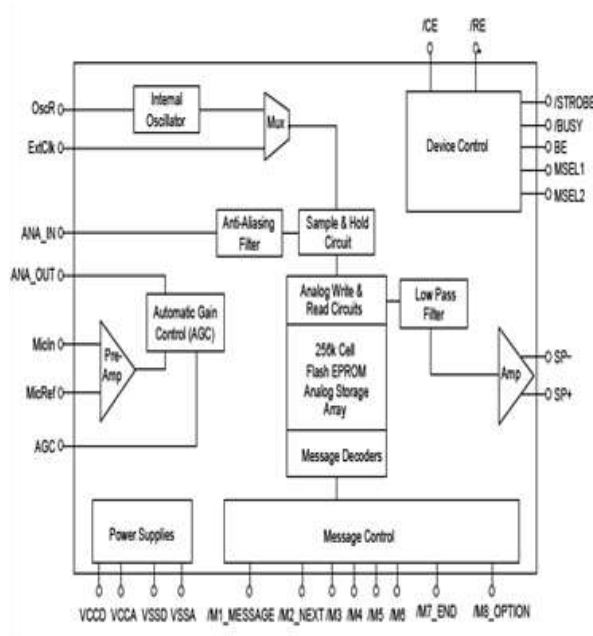

Figure: APR 9600 Block diagram

### General description

APR9600 device offers true single-chip voice recording, on-volatile storage and playback capacity for 60 to 80 seconds. The device supports both random and sequential access of multiple messages. Samples rates are user-selectable allowing designer to customize their design for unique quality and storage time needs integrated output amplifier, microphone amplifier and AGS circuits greatly simplify system design the device is ideal for portable voice recorders, toys and many other consumer and industrial application.

APLUS integrated achieves high levels of storage capability by using its proprietary analog/multilevel technology implemented in an advanced flash, non-volatile, memory process where each cell can store 256 voltage levels. This technology enables 9600 device to reproduce voice signals in their natural form. It eliminates need for encoding and compression, which often introduce distortion.

### Functional description

APR9600 block diagram is included in order describe the devices internal architecture. At the left hand side of the diagram are the analog inputs. A differential microphone amplifier, including integrated AGC is included on-chip for applications requiring use. The amplified microphone signal fed into the device by connecting the ANA-OUT pin to the ANA-IN pin through an external DC blocking capacitor. However,

the connecting between ANA-OUT is still required for playback. The next block encountered by the input signal is the internal anti-aliasing filter.

The filter automatically adjust its response according to the sampling frequency selected to Shannon's sampling Theorem is satisfied after anti-aliasing filtering is accomplished through a combination of the Sample and Hold circuit and the Analog write/read circuit. These circuits are clocked by either the internal oscillator or an external clock source. When playback is desired the previously storage recording is retrieved from memory, low pass filtered, and amplified as shown on the right hand side of the diagram. The signal can be heard by connecting a speaker to the SP+ and SP-pins chip-wide management is accomplished through the device control block shown in the upper right hand corner. Message Management is provided through the message control block represent in the lower center of block diagram. More detail on sampling control can be found in the sampling rate & Voice quality Section more detail on message management & device control can be found in the message management section.

### Message management

Playback and record operations are managed by on-chip circuitry. These are several available messaging modes depending upon desired operation. These message modes determine style, message length and external parts count.

### Random access mode

Random Access Mode supports 2, 4 or 8 message segment of fixed duration. As suggested recording or playback can be made randomly in any selected messages. The length of each message segment is the recording length available (as defined by the selected sampling rate) divided by the total number of segment enabled. Random access mode provides easy indexing to message segments.

### Fundamental Description of recording in Random access mode

On power up, the device is ready to record or playback any of the enabled message segments. To record/CE must be set low to enable the device and/RE must be set low to enable recording. You initiate recording by applying a low level on the message trigger pin that represent the message segment you intend to use. The message trigger pins are labeled /M1-message, /M8-OPTION on pin 1-9 (excluding pin 7) for message segment 1-8 respectively.



Note:-Message trigger pins of M1-MESSAGE, /M2-NEXT, /M7-END, AND /M8-OPTION, have expanded names to represent the different functionality that these pins assume in the other modes. In random access mode these pins should be considered purely message trigger pins with the same functionality as /M3, /M4, /M5 and /M6 for a more through explanation of the functionality of device pin in different modes. When actual recording. Recording continues as long as the message pin stays low.

#### **Functional description of playback random access mode**

On power up, the device is ready to record or playback, in any of the enabled message segments. To playback, /CE must be set low to enable the device & /RE must be set high to disable recording & enable playback. You initiate playback by applying a high to low edge on the message trigger pin that represents the message segment you intend to playback will continue until the end of message is reached.

#### **Conclusion**

A dashboard is a control panel placed in front of the driver of an automobile, housing instrumentation and controls for operation of the vehicle. The voice annunciation is important because while driving, driver may not pay much attention towards the display since he is concentrating on the driving, but the voice announcement will let him hear about the alerts directly through the car speakers thereby reducing time and increasing efficiency of the system. In this way, with the help of car dashboard, we can get visual as well as voice annunciation of performance measures.

#### **References**

- [1] Min Goo Lee, Kyung Kwon Jung and Jun Jae Yoo, " Estimation of fuel consumption using vehicle-in parameters" *International Journal of u- and e- Service, Science and Technology* Vol. 4, No. 4, December, 2011
- [2] Gergely Fordos, Istvan Bosznai and Levente Kovacs, "Sensor-net for Monitoring Vital Parameters of Vehicle Drivers", Vol. 4, No. 4, 2007
- [3] Paul Kretz, Jerry Robin, and Martin Walker "Onboard Monitoring and Reporting for Commercial Motor Vehicle Safety", Report No. FMCSA-RRT-07-030, December 2007
- [4] National Highway Traffic Safety Administration (2003) *Traffic Safety Facts*

2003: (DOT HS 809 775 and DOT HS 809 763) Washington, DC: National Centre for Statistics and Analysis[<http://www.nhtsa.dot.gov/people/nca>]

#### **Author Bibliography**



**Shinde Sandhya V.**  
B.Tech(E&TC)  
Dr.B.A.T.University,Lonere  
Email:  
san33625@gmail.com